

MATERIALS AND PRODUCTS CATALOG



Metalska industrija Varaždin d.d.

www.strojar.hr

COPPER ALLOY FOUNDRY AND MANUFACTURING OF MACHINE PARTS



Strojar d.o.o is leading manufacturer of copper based alloys in Croatia. Founded 60 years ago today it is positioned as manufacturer of high value and high quality products thanks to internal chemical and mechanical laboratory. Det Norske Veritas certified manufacturing of bronze and brass to be in accordance with ISO 9001:2008 quality assurance standard. Enterprise has several hundreds costumers from areas of naval engineering, engine and aggregate manufacturing, process industry and other industry branches. More then 50% of production is sold on European Union markets like Austria, Slovenia and Germany.

Manufacturing facility has 250.000 kg yearly production capacity of various products. Capacity of furnaces allows manufacturing of up to 3000 kg heavy casts, and machining can be made on rings up to 2400 mm in diameter. Enterprise can make over 30 different alloys of bronze and brass, including tin bronze, aluminum bronze, aluminum nickel bronze, lead bronze, and other types of multi component bronzes, while brases are most often made as alloys of copper and zinc with addition of led. Core product selection are centrifugally cast plain bearings, bushings, rings, nuts and other machine parts, while smaller part of product selection is made by casting in metal



and sand molds. Equipment for centrifugal cast allows for casts up to 3000 kg in mass, form 80 to 1400 mm in diameter and up to 1400 mm in length. Centrifugally casting technology provides better homogeneity of material and improved mechanical properties when compared to bronze and brass made with continuous cast, or cast in to metal and sand molds.

All manufacturing processes comply with environmental protections requirements. Waste products are handled in legality required way, as are other measures and measurements dictated by environmental protection laws and regulations. Ministry of environmental protection ensures compliance by regular inspections.

Company produces all materials listed in this catalog. If there is a need for material not in listed within feedback information on possibility of manufacture can be provided on request.

PRODUCT SELECTION

LIST OF PRODUCED MATERIALS

Bronze

Bronzes that can be used to produce any item from product selection are:

• CuSn5	• CuPb15Sn8	• CuAl9Mn2
• CuSn10	• CuPb17Sn10	• CuAl10Fe3
• CuSn12	• CuPb20Sn5	• CuAl10Fe3Mn2
• CuSn12Ni2	• CuSn7Zn4Pb7	• CuAl9Ni
• CuSn11Pb2	• CuSn6Pb3Zn2Ni	• CuAl10Fe5Ni5
• CuSn14	• CuSn5Pb5Zn5	• CuAl11Fe6Ni6
• CuPb10Sn5	• CuSn10Zn2	• CuNi12Sn2Pb3Zn20
• CuPb10Sn10	• CuAl9	

Brass

Brasses that can be used to produce any item from production program are:

• CuZn15	• CuZn34Al2
• CuZn40	• CuZn35Mn2Al1Fe1
• CuZn33Pb2	• CuZn20Al2
• CuZn37Pb	• CuZn37Al1
• CuZn39Pb2	• CuZn40Al1
• CuZn25Al5	• CuZn40Al2

On customer request other materials, based on different norms (UNI, ATSM, GOST...), can be used. In that case size of order should be at least 300 kg.



Product selection is made from following categories:

1. Round full bars
2. Pipes and rings
3. Bushings with single flange
4. Bushings with double flange
5. Nuts (thick walled pipes)
6. Split pipes and rings
7. Split bushings with single flange
8. Split bushings with double flange
9. Slide rails and plates
10. Slide rings
11. Sand molded cast
12. Ingots

Centrifugal cast makes over 90% of product selection. This secures improved homogeneity of structure and better mechanical properties when compared to alternative production methods.



AD 1. ROUND FULL BARS

Round full bars are made by casting in metal molds.

Standard length of the piece is 300 mm, other lengths are also possible depending on the customer's request.

Possible diameters of the bars range from 10 mm to 300 mm.

Measures for order are:

D – bar diameter, mm

L – bar length, mm

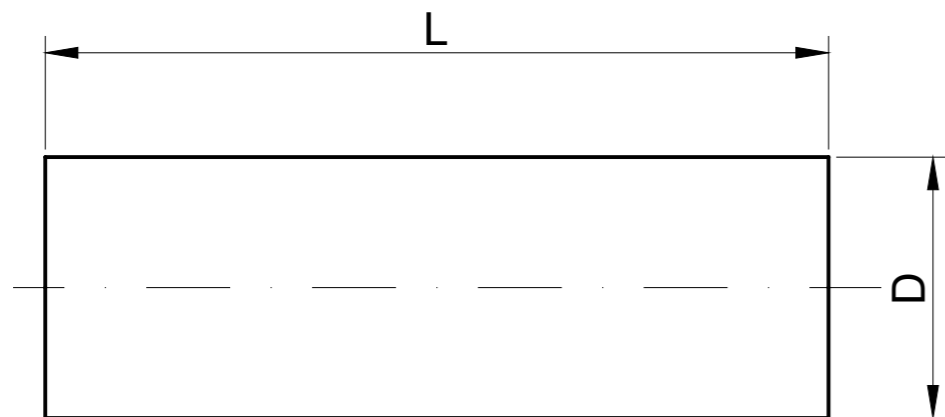

AD 2. PIPES AND RINGS

Pipes and rings are made with centrifugal cast that allows for improved homogeneity of structure, and better mechanical properties, when compared to product made by sand mould cast and continuous cast.

Standard length of product is 300 mm. Depending on diameter maximal product length can go up to 1410 mm.

Possible diameters for pipes and rings range from 80 mm up to 1410 mm..

Measures for order are:

OD – pipe or ring outer diameter, mm

ID – pipe or ring inner diameter, mm

L - pipe or ring length, mm

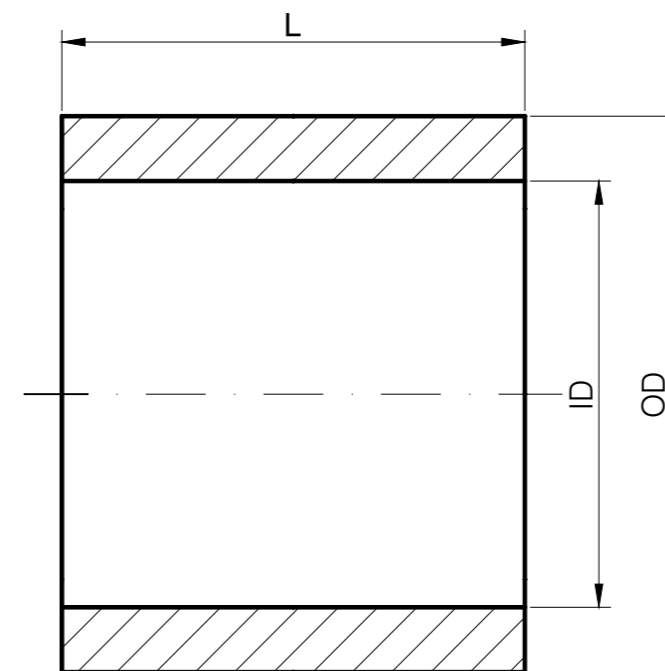

Table lists all measurements of pipes and rings that can be made.

OD – pipe or ring outer diameter, mm

Smax – maximal thickness of the pipe wall, mm

Smin – minimal thickness of the pipe wall, mm

Lstandart – standard length, mm

Lmax – maximal possible length, mm



OD, mm	Smax, mm	Smin, mm	L standard, mm	L max, mm
80 - 90	15	4	300	400
91-100	20	4	300	400
101-110	25	4	300	600
111-130	30	4	300	600
131-150	40	4	300	400
151-160	45	4	300	600
161-170	45	4	300	600
171-180	45	4	300	1020
181-200	50	4	300	350
201-220	50	5	300	500
221-230	55	5	300	700
231-260	60	5	300	1250
261-270	65	5	300	450
271-290	70	5	300	730
291-300	70	5	300	450
301-310	75	6	300	1530
311-320	75	6	300	490
321-330	80	6	300	1000
331-340	80	6	300	520
341-360	85	6	300	360
361-370	85	6	300	800
371-380	90	6	300	420

OD, mm	Smax, mm	Smin, mm	L standard, mm	L max, mm
381-400	90	6	300	610
401-410	95	7	300	680
411-430	100	7	300	700
431-440	100	7	300	1450
441-460	100	7	300	1000
461-470	100	7	300	700
471-485	100	7	200	420
486-505	100	7	150	520
506-525	100	8	320	1200
526-550	100	8	300	1000
551-560	100	8	300	520
561-570	100	8	300	440
571-590	100	8	300	780
591-605	100	8	300	480
606-625	100	8	600	600
626-635	100	8	600	1450
636-650	100	8	400	700
651-665	100	8	250	250
666-680	100	8	300	300
681-695	100	8	600	600
696-705	100	8	670	670
706-715	100	8	750	750



AD 3. BUSHINGS WITH SINGLE FLANGE

Bushings with single flange are made with centrifugal cast, and they can be ordered up to a maximum outer diameter of 1420 mm, and maximum length of 1530 mm

Measures for order are:

L – bushing overall length, mm

L1 – flange length, mm

D1 – flange outer diameter, mm

D2 – body outer diameter, mm

D3 – inner diameter, mm

OD, mm	Smax, mm	Smin, mm	L standard, mm	L max, mm
716-750	100	8	700	700
751-770	100	8	300	700
771-785	100	8	200	200
786-805	100	8	500	500
840-855	100	9	920	920
856-870	90	9	360	360
871-905	90	9	400	400
906-920	90	9	100	850
921-930	90	9	900	900
931-980	90	9	350	350
981-1055	80	10	300	300
1056-1080	80	10	150	150
1081-1100	80	10	710	710
1101-1125	80	10	250	250
1126-1160	80	10	1050	1050
1161-1175	80	10	170	170
1176-1200	80	10	150	150
1201-1235	80	10	150	150
1236-1260	80	10	80	80
1261-1295	80	10	220	220
1296-1335	80	10	190	190
1336-1380	80	12	260	260
1381-1410	80	12	120	120

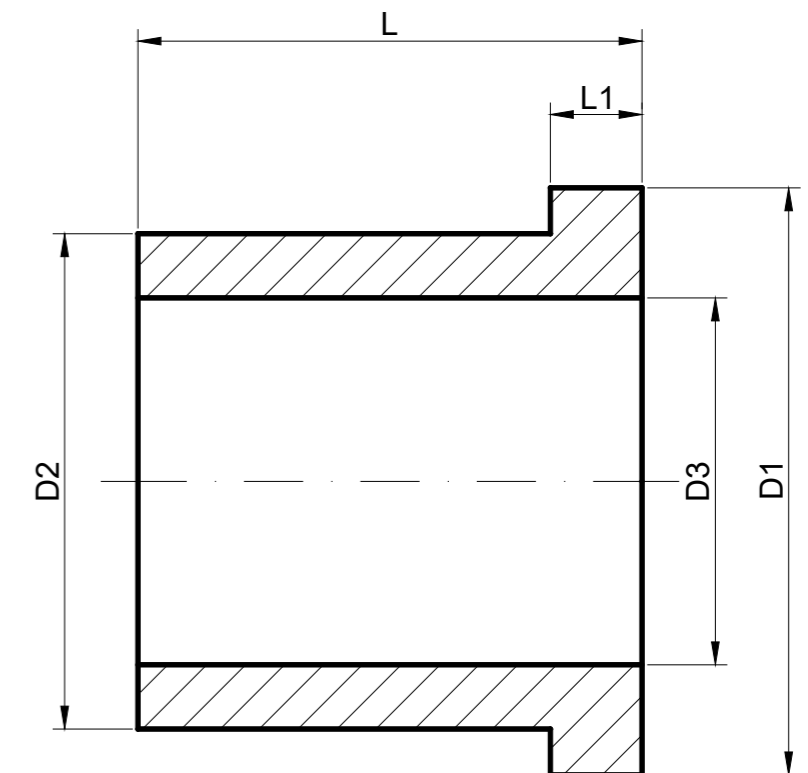

AD 4. BUSHINGS WITH DOUBLE FLANGE

Bushings with double flange are made with centrifugal cast, and they can be ordered up to a maximum outer diameter of 1420 mm, and maximum length of 1530 mm.

Measures for order are:

L – bushing overall length, mm

L1 – length of the first flange, mm

L2 – length of the second flange, mm

D1 – outer diameter of the first flange, mm

D2 – outer diameter of the second flange, mm

OD – body outer diameter, mm

ID – inner diameter, mm

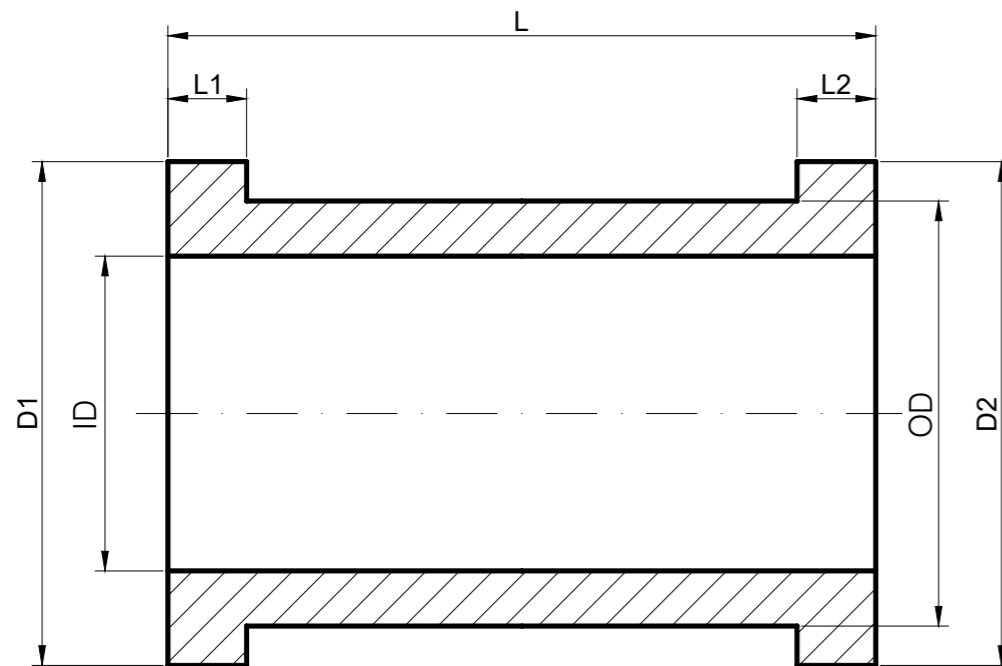

AD 5. NUTS (THICK WALLED PIPES)

Nuts are made with centrifugal cast, and they can be ordered up to a maximum outer diameter of 1420 mm and maximum length of 1530 mm. Centrifugal cast allows for improved homogeneity of structure when compared with other casting methods, which is especially important for products that have thread cut on the inner diameter.

Measures for order are:

OD – outer nut diameter, mm

ID – inner nut diameter, mm

L – nut length, mm

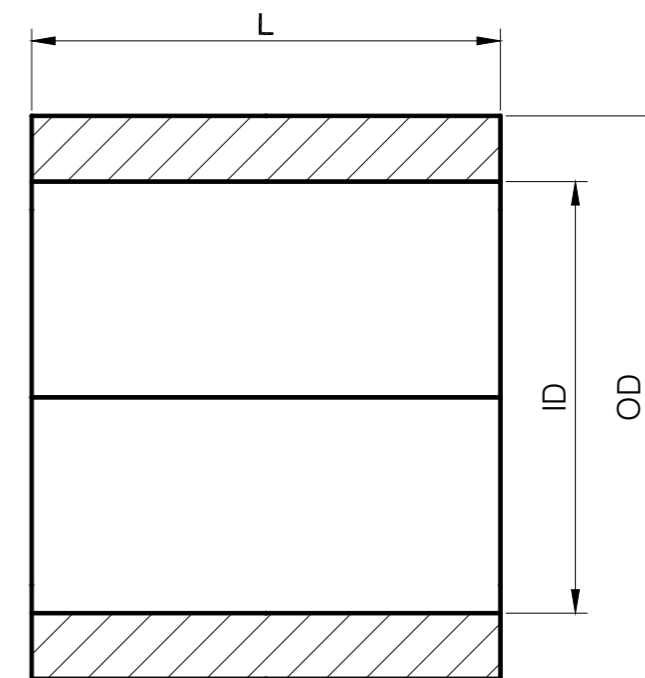

AD 6. SPLIT PIPES AND RINGS

Split pipes and rings are used as bearings on shafts that don't allow for installation of single piece bearing. Split pipes and rings are made with centrifugal cast and delivered rough machined to required dimensions, soldered or frontally welded together.

Measures for order are:

OD – pipe or ring outer diameter, mm

ID – pipe or ring inner diameter, mm

L – pipe or ring length, mm

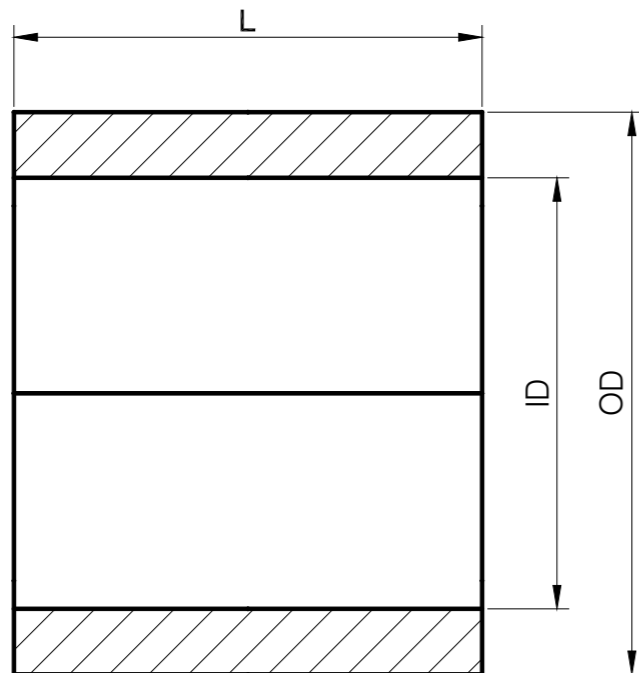

AD 7 SPLIT BUSHINGS WITH SINGLE FLANGE

Split bushings with single flange are used as bearings on shafts that don't allow for installation of single piece bearing. Split pipes and rings are made with centrifugal cast and delivered rough machined to required dimensions, soldered or frontally welded together.

Measures for order are:

L – bushing overall length, mm

L1 – flange length, mm

D1 – flange outer diameter, mm

D2 – body outer diameter, mm

D3 – inner diameter, mm

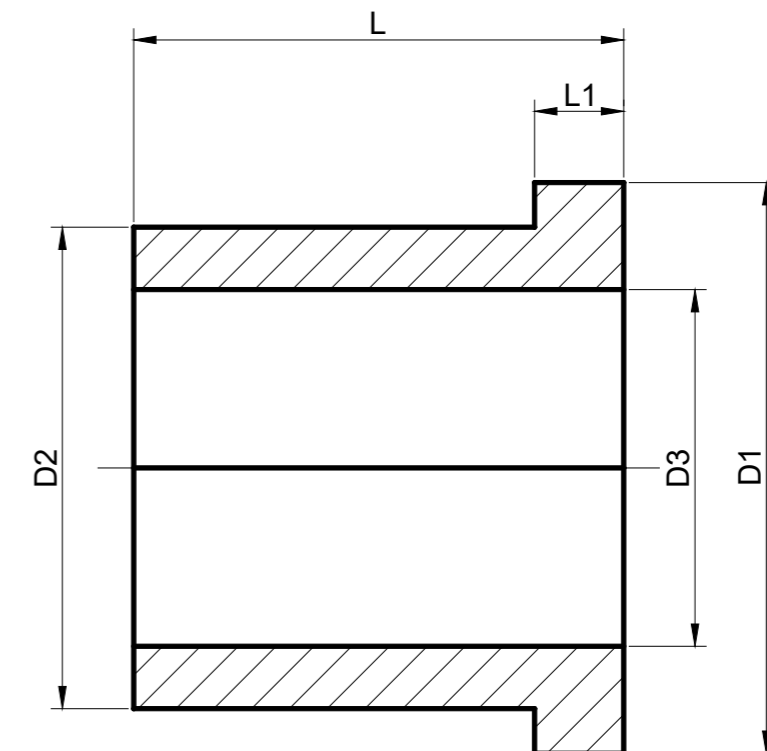

AD. 8. SPLIT BUSHINGS WITH DOUBLE FLANGE

Split bushings with double flange are used as bearings on shafts that don't allow for installation of single piece bearing. Split pipes and rings are made with centrifugal cast and delivered rough machined to required dimensions, soldered or frontally welded together.

Measures for order are:

- L** – bushing overall length, mm
- L1** – length of the first flange, mm
- L2** – length of the second flange, mm
- D1** – outer diameter of the first flange, mm
- D2** – outer diameter of the second flange, mm
- OD** – body outer diameter, mm
- ID** – inner diameter, mm

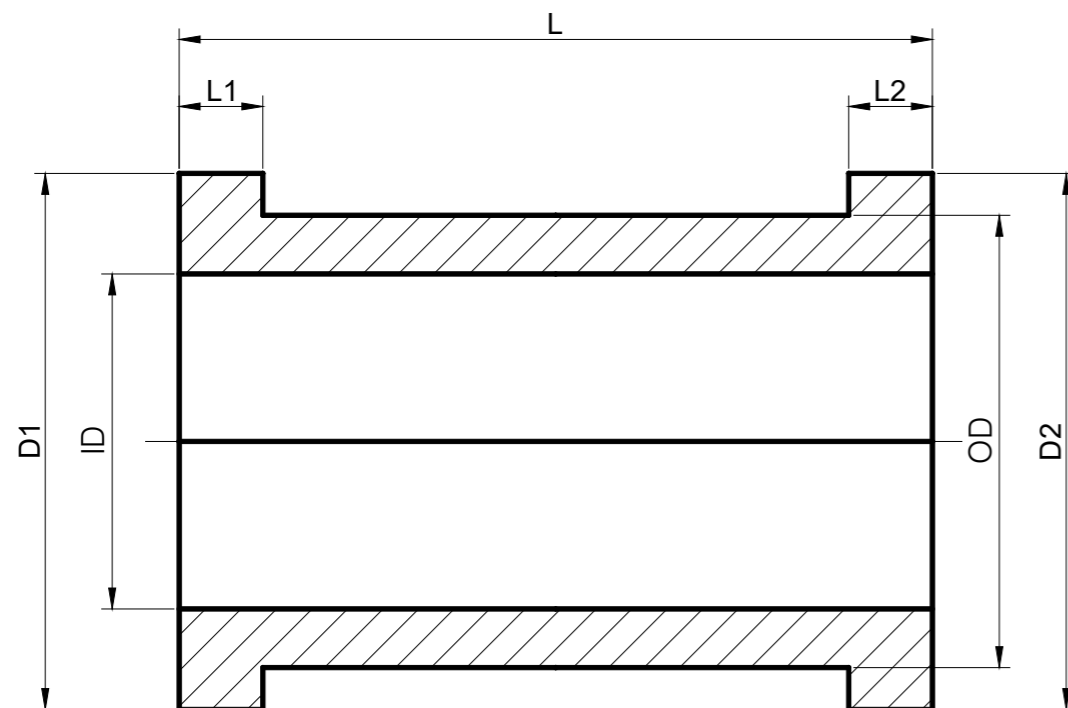

AD 9. SLIDE RAILS AND PLATES

Slide rails and plates are cast in static metal molds. They are used for machine slide surfaces.

They can be ordered with width up to 300 mm, thickness up to 100 mm and length up to 1000 mm.

Measures for order are:

- L1** – slide rail thickness, mm
- L2** – slide rail width, mm
- L3** – slide rail length, mm

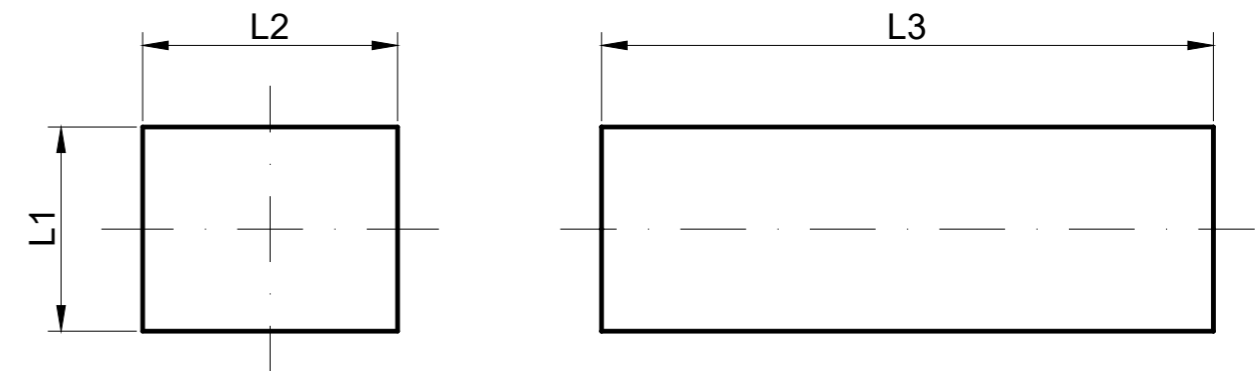

AD 10. SLIDE RINGS

Slide rings are large diameter machine parts uses in power plants and machine construction.

Slide rings can be ordered with diameters from 1400 mm up to 2600 mm, height up to 200mm.

Measures for order are:

OD – ring outer diameter, mm

ID – ring inner diameter, mm

H – ring height, mm



AD 11. SAND MOLDED CAST

Two methods can be used to make sand moulds:

- green sand moulding (soft molds)
- CO₂ moulding (hard molds)

Casting can be made with patterns provided by the costumer, or with new patterns made according to documentation delivered by customer.



AD 12. INGOTS

Ingots are cast according to the need of the customer. Orders can be made for ingots with mass cca. 12-15 kg from any material in standard material selection, with minimal order mass of 200 kg.



Certificates of chemical composition and mechanical properties (yield strength, tensile-strength, elongation, hardness HB 10) can be provided from our laboratories.





METALSKA INDUSTRIJA VARAŽDIN d.d.



Fabijanska 33
42 000 Varaždin
Croatia

Casting and sale of non-ferrous metals sector
Bistranska 214
Gornja Bistra
HR-10298 Donja Bistra

Tel: 00385(0)1 3390 019,
00385(0)1 3390 023
Fax: 00385(0)1 3390 028
Mail: info@miv.hr

www.strojar.hr

Registration number of company: 3224171
VAT number: HR95240603723
IBAN: HR9525000091501148428, Addiko bank d.d.
IBAN: HR5523600001502400855, Zagrebačka banka d.d.